

# SN60MC Metal Connector Nailer

with the *Precise Point™* Hole Locator System

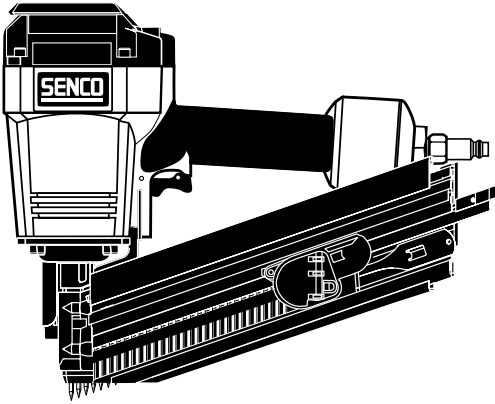

The Senco SN60MC nailer is designed for areas where codes call for metal connectors. The *Precise Point™* Hole Locator System uses the nail point for faster and simpler hole location, increasing productivity by 50% over hand nailing. With its compact design

and versatile magazine angle, the Senco SN60MC fits into tight spots to accurately fasten the full range of metal connectors. Its comfort-grip handle and easy two-step loading accommodate both left- and right-hand users. And, with the strongest, moisture-resistant fastener tape collation in the industry, it helps ensure full nail strips.

---

## Applications:

---

For use with metal connector joist hangers, straps, ties, hold downs and anchors.

---

## Features:

---

- Drives .131", .148", and .162" shank diameter nails in lengths of 1-1/2" and 2-1/2"
- Just 7.7 pounds for easy one-handed operation
- Compact design for maneuverability in tight spots
- *Precise Point™* Hole Location System
- Ergonomic comfort-grip handle reduces vibration and fatigue
- Drives nails flush without damaging the connectors
- Moisture-resistant tape collation is the strongest in the industry



# SN60MC Metal Connector Nailer

## Tool Specifications:

Tool Weight: 7.7 lbs. (3.5 kg)  
 Height: 12 <sup>13</sup>/<sub>16</sub>" (325mm)  
 Length: 14" (365mm)  
 Width: 4 <sup>5</sup>/<sub>8</sub>" (109mm)  
 Magazine Capacity: 30  
 Operating Pressure: 80-120 p.s.i.g. (5.5- 8.3 bar)  
 Mode of Operation: Tools are only available with "Restrictive Trigger" activating mechanism.\*  
 Hose Fitting: 1/4" (6mm)

## Fastener Specifications:

Drives .131", .148" and .162" full round-head framing nails in lengths of 1 1/2" and 2 1/2".



Made in the U.S.A.

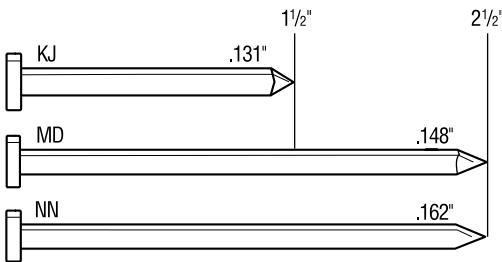

Available in Bright Basic and Hot Dipped Galvanized

## Other Metal Connector Tools: A9 Palm Nailer

For those tight spots, the Senco A9 Palm Nailer is all you need. At 2.5 lbs., the Senco A9 Palm Nailer increases your productivity while reducing fatigue. With a Depth-of-Drive Control, the tool will drive the fasteners flush without damaging the connectors.

The Senco SN60MC and A9 Palm Nailer, the only tools you need for simpler, faster connecting!



\*\*Dimensions shown may be converted to metric on basis of 1" = 25.40 millimeters (mm) rounded to the nearest 5mm.

\* "Restrictive Trigger" activated tools are used for applications where precision nail or staple placement is desired. You must first depress the safety element where you want to drive a nail and then pull the trigger. After each nail is driven, completely release the trigger and lift the tool off the work surface.

For additional information on how Senco fastening systems will save you time, reduce costs, and increase quality, call your nearest Authorized Senco Dealer or Distributor listed in the Yellow Pages under "Staples," or call our toll-free Action Line: 1-800-543-4596.