

Clinching Staplers D & F Series

Lightweight tools feature self-contained staple driving clinching ability

SENCO's extremely lightweight (2.7 lbs.) D Series Staplers are designed for packaging applications. SENCO's F Series Staplers are widely used in packaging, display, and bedding applications where staples must be driven and clinched. Special throat depths are available for sisal models and packaging models. The D & F Series Staplers provide excellent performance with a minimum of maintenance.

Applications:

Used wherever two materials must be stapled and clinched.

D Series: Used in light assembly operations joining wood and corrugated or other materials together. In shoemaking, used for attaching wooden or steel shanks, upper to insoles, vamps, straps, ornaments, and buckles. Widely used in corrugated box fabrication. **F Series:** For stapling sisal and other fillers in bedding. Ideal for recessed-end packaging, preassembly setup, boxes, and displays. As a cutting-room stapler for shoemaking, it fastens material up to 20-ply thick.



D Series
The DFP stapler drives
F Series staples.



F Series
The F75 drives
J Series staples.

Features:

The easy handling and speed of the D & F Series Staplers cut fastening time dramatically, reduce fabrication costs, and virtually eliminate operator fatigue. Least experienced employees can reach operating proficiency in a couple of hours. These staplers are designed for minimum maintenance, fast loading and long service life.



Clinching Staplers D & F Series

Tool Specifications:

D Series

Tool Weight: 2.7 lbs. (1.2 kg)
 Height: 7-3/8" (187 mm)
 Length: 8" (203 mm)
 Lip Length: 1/2" (13 mm)
 Jaw Openings: 9/16" or 13/16"
 Throat Depth: 4-3/4"
 Staple Capacity: 112-168, in various lengths and gauges

F Series

Tool Weight: 4.1 to 4.2 lbs. (1.9 kg)
 Height: 9-13/16" to 10-3/4" (249 mm to 273 mm)
 Length: 14-5/8" (371 mm)
 Lip Length: 1/2" to 5/8" (13 to 16 mm)
 Throat Depth: 1-1/2" or 4" with sisal models; 4-3/4" with packaging models
 Staple Capacity: 146-224, in various lengths and gauges
 Air pressured required for both tools: 70-90 p.s.i.g.

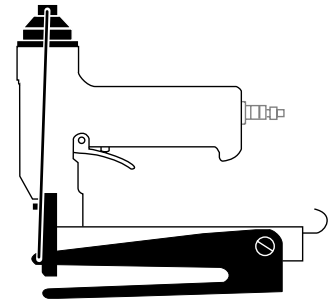

D Series

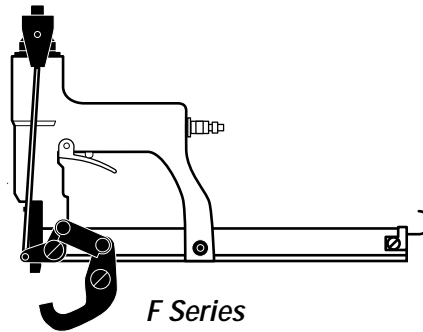

F Series

Fastener Specifications:

F Series

Crown: 1/2"
 Width: .50", Thickness: .019"

J Series

Crown: 7/16"
 Width: .075", Thickness: .023"

| Lengths | Inches | 3/16" | 1/4" | 5/16" | 3/8" | 1/2" | 5/8" |
|----------|-------------|--------|--------|--------|--------|--------|--------|
| Part No. | Millimeters | F05BAA | F06BAA | F08BAA | J06BAA | J08BAA | J10BAA |



Dimensions shown may be converted into metric measure on basis of 1" = 25.40 millimeters (mm).



D Series The DFP stapler drives F Series staples.

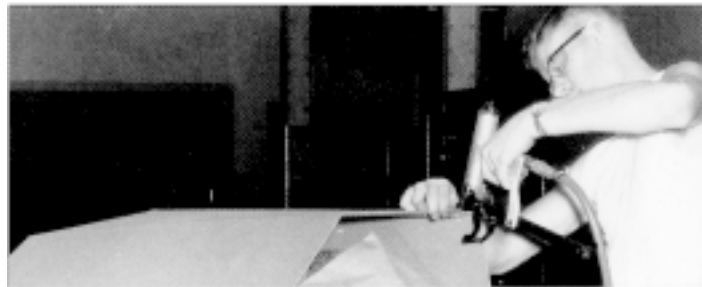

F Series The F75 drives J Series staples.

For additional information on how SENCO fastening systems will save you time, reduce costs, and increase quality, call your nearest Authorized SENCO Dealer or Distributor listed in the Yellow Pages under "Staples," or call our toll-free Action Line: 1-800-543-4596.