

NEW!

SENCO®

FramePro® 650 Nailer



The FramePro® 650 Nailers have all the features you want. These compact framers are easy to handle, and easy on the arm. Their 30° short, in-line magazines, provide excellent maneuverability and line of sight. These powerful framers drive a wide range of fasteners in 4 gauges (.113 - .148) from 2" to 3-1/2" to handle virtually any job.

Applications:

For framing, truss building, subflooring, sheathing, decking, siding, fencing, pallets and crate assembly.

Features:

- Aggressive sawtooth safety that really digs in for toenailing
- Shorter, straight-line 30° magazine for better line of sight and maneuverability
- Drives ring, screw, and smooth shank nails in 4 gauges (.113 - .148) from 2" to 3-1/2"
- Highly reliable internal design with full round driver
- Adjustable exhaust
- Lightweight with 10% more power than the 600
- Depth-of-drive control, and E-Z Clear
- Ergonomic comfort grip handle reduces vibration and fatigue
- One year warranty

Tool Specifications:

Tool Weight: 8.4 (3.8kg)

Height: 14-1/2" (362mm)

Length: 15" (384mm)

Nail Capacity: 56-80, depending on gauge

Reg. Operating Pressure: 70-120 p.s.i.g.

Mode of Operation: Available with Restrictive Trigger or Dual Action activating mechanisms.

For additional information on how Senco fastening systems will save you time, reduce costs, and increase quality, call your nearest Authorized Senco Dealer or Distributor listed in the Yellow Pages under "Staples," or call our toll-free Action Line: 1 800 542-4596. Visit our Web site: www.senco.com

Fastener Specifications:

FramePro 650 nailer drives 2" through 3-1/2" smooth shank nails Sencote® or plain; 2" to 3" ring-shank nails; 3" screw-shank and clipped "D" head nails. Shank diameters include .113", .120", .131" and .148".

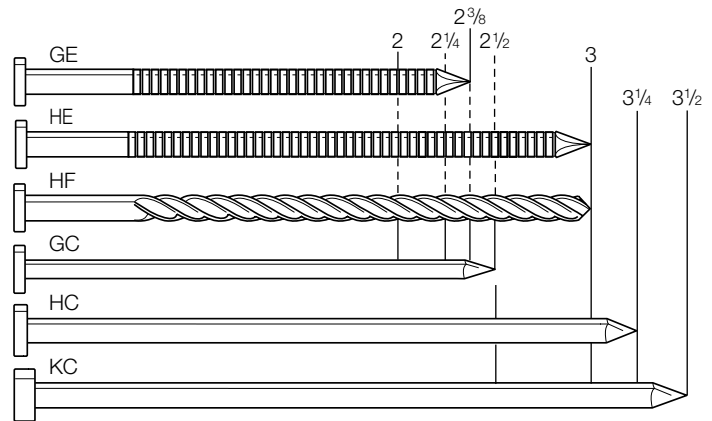

* "Restrictive Trigger" activated tools are used for applications where precision nail or staple placement is desired. You must first depress the safety element where you want to drive a nail or staple and then pull the trigger. After each nail or staple is driven, completely release the trigger and lift the tool off the work surface.

"Dual Action" activated tools are used for applications where high-production work is desired. There are two modes of operation:

Bottom Fire Method: This method of operation is sometimes called bounce firing. You must keep the trigger pulled while moving the tool along the work surface with a bouncing motion, depressing the safety element where you want to drive a nail or staple.

Trigger Fire Method: First depress the safety element where you want to drive a nail or staple and then pull the trigger.

For instructions on safe use of tools with either of these activating mechanisms, please refer to the Operating Instructions or Customer Satisfaction and Safety Reminder contained in your tool carton.