

# FramePro® 502 Framing Nailer

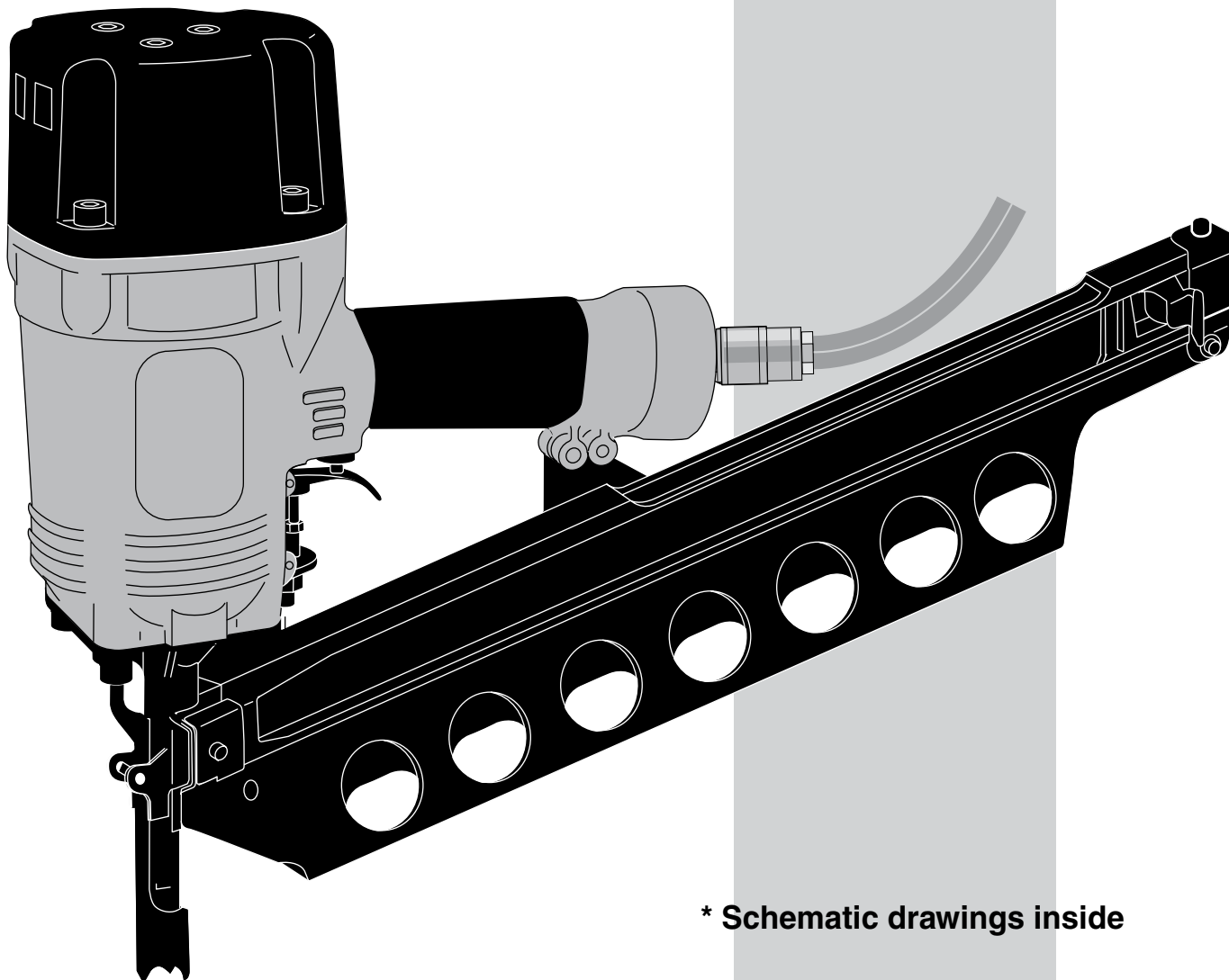

## Parts Reference Guide



\* Schematic drawings inside

Senco Products, Inc.  
8485 Broadwell Rd.  
Cincinnati, Ohio 45244

Questions? Comments? call SENCO's toll-free Action-line:  
1-800-543-4596 (North & South America only)  
or e-mail: [toolprof@senco.com](mailto:toolprof@senco.com)

Visit our Website [www.senco.com](http://www.senco.com)

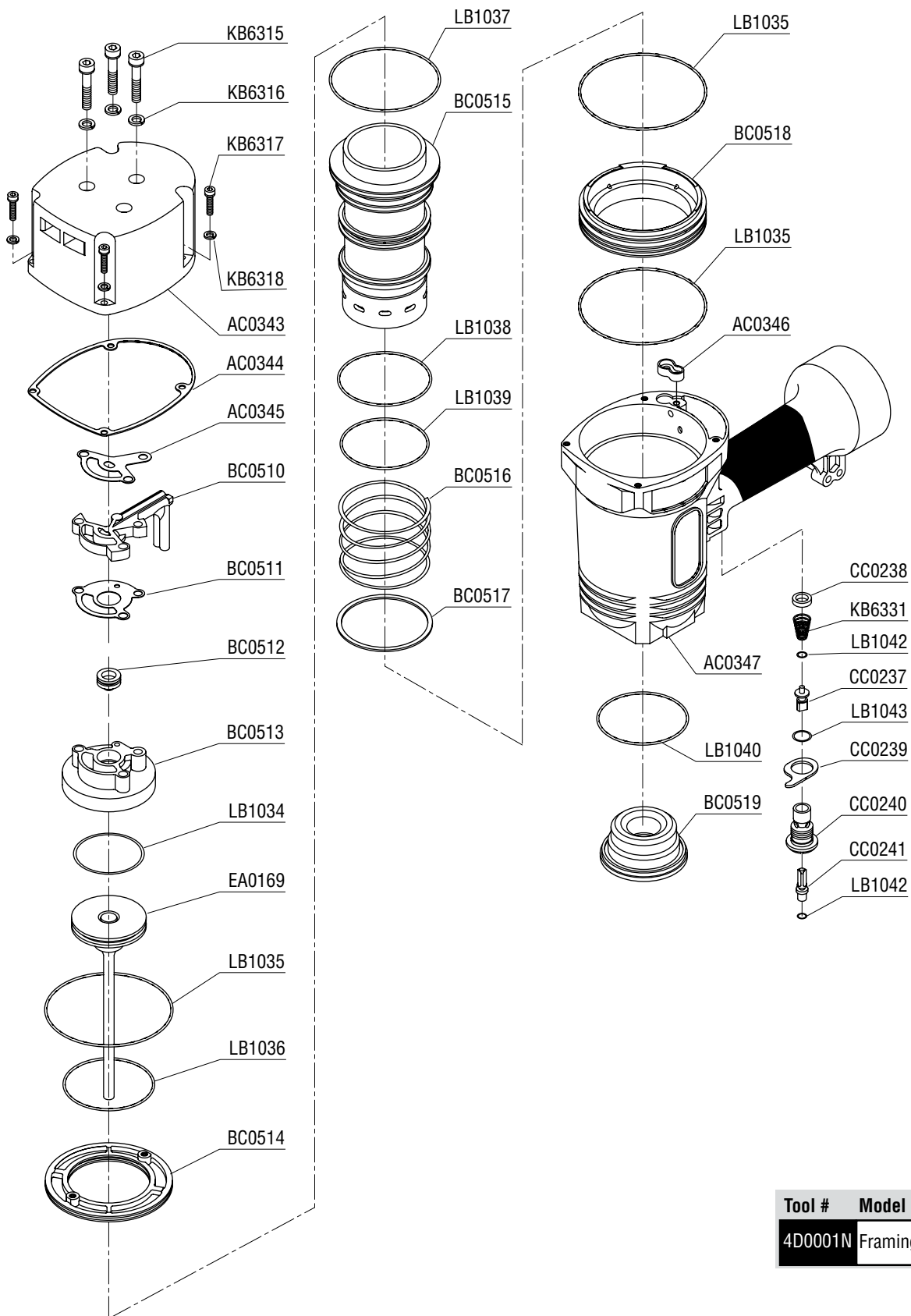

Tool #	Model
4D0001N	Framing Nailer

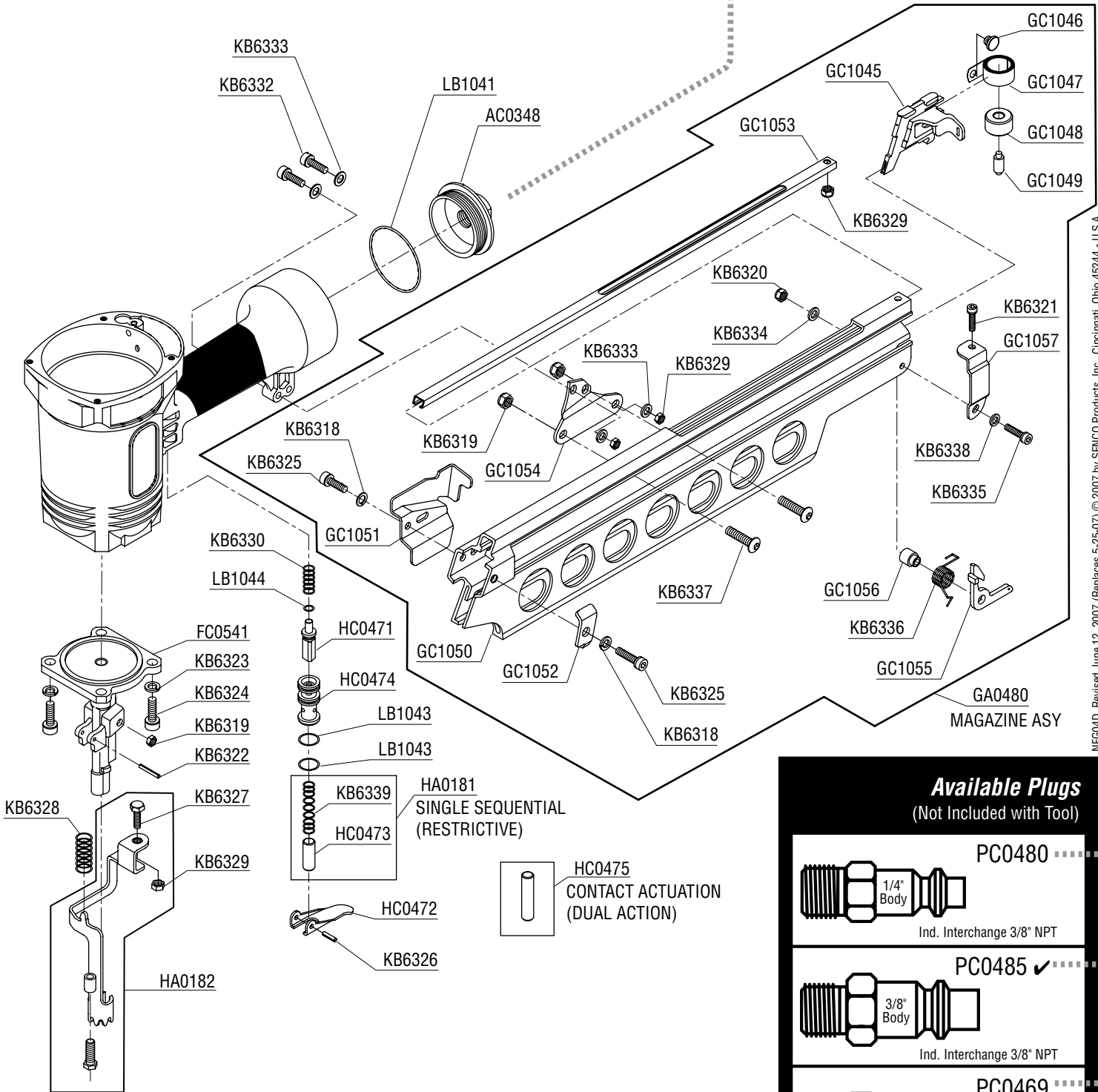

# FramePro® 502

**SENCO®**

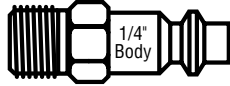
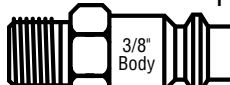

NFG04D Revised June 12, 2007 (Replaces 5-25-07) © 2007 by Senco Products, Inc. Cincinnati, Ohio 45244 - U.S.A.

**Available Plugs**  
(Not Included with Tool)

	<b>PC0480</b>
	Ind. Interchange 3/8" NPT
	<b>PC0485</b> ✓
	Ind. Interchange 3/8" NPT
	<b>PC0469</b>
	Tru-Flate 3/8" NPT
	<b>PC0475</b> ✓
	Tru-Flate 3/8" NPT

✓ **Recommended Plugs**  
Plugs shown smaller than actual size

# FramePro® 502 Framing Nailer

REPLACEMENT PARTS LIST • LISTA DE PARTES DE REPUESTO • ERSATZTEILE-LISTE • LISTE DE PIÈCES DE RECHANGE

PART NO.	DESCRIPTION	DESCRIPCIÓN	BESCHREIBUNG	DÉSIGNATION
AC0343	CAP	TAPA	KAPPE	BOUCHON
AC0344	SEAL (GASKET)	SELLO	DICHTUNG	JOINT
AC0345	SEAL (GASKET)	SELLO	DICHTUNG	JOINT
AC0346	SEAL (GASKET)	SELLO	DICHTUNG	JOINT
AC0347	MAINBODY	CARCASA	GEHÄUSE	CORPS
AC0348	END CAP	TAPA TERMINAL	ABSCHLUßKAPPE	BOUCHON D'EXTRÉMITÉ DE RAIL
BC0510	DEFLECTOR	DESVIADOR	ABWEISER	DÉFLECTEUR
BC0511	SEAL (GASKET)	SELLO	DICHTUNG	JOINT
BC0512	VALVE (EXHAUST)	VÁLVULA	VENTIL	VALVE
BC0513	VALVE	VÁLVULA	VENTIL	VALVE
BC0514	PLATE (SLEEVE ADAPTOR)	PLACA	PLATTE	PLAQUE
BC0515	CYLINDER	CILINDRO	ZYLINDER	CYLINDRE
BC0516	SPRING	RESORTE	FEDER	RESSORT
BC0517	WASHER	ARANDELA	SCHEIBE	RONDELLE
BC0518	RING	ANILLO	REIFEN	ANNEAU
BC0519	STOP, PISTON	TOPE	PUFFER	ARRÊT
CC0237	CORE	VÁSTAGO	VENTILSTIFT	NOYAU
CC0238	SEAL (GASKET)	SELLO	DICHTUNG	JOINT
CC0239	WASHER	ARANDELA	SCHEIBE	RONDELLE
CC0240	CAGE (REMOTE)	CAJA	KÄFIG	CAGE
CC0241	CORE	VÁSTAGO	VENTILSTIFT	NOYAU
EA0169	PISTON/DRIVER ASSY	ASAMBLE DE PISYON Y	KOLBEN/TREIBER	PISTON/COUTEAU
FC0541	GUIDE BODY	PLACA DE NARIZ	NAGELFÜHRUNG	FRONT
GA0480	MAGAZINE ASSY	CARGADOR	MAGAZIN	MAGASIN
GC1045	FEEDER SHOE	ALIMENTADOR	NAGELSCHIEBER	POUSSOIR
GC1046	RETAINER	RETÉN	SICHERUNGSRING	RETENUE
GC1047	SPRING	RESORTE	FEDER	RESSORT
GC1048	ROLLER	RODILLO	ROLLE	GALET
GC1049	PIN	PASADOR	STIFT	GOUPILLE
GC1050	MAGAZINE	CARGADOR	MAGAZIN	MAGASIN
GC1051	PLATE (WEAR)	PLACA	PLATTE	PLAQUE
GC1052	PLATE (WEAR)	PLACA	PLATTE	PLAQUE
GC1053	PLATE (WEAR)	PLACA	PLATTE	PLAQUE
GC1054	BRACKET	SOPORTE	HALTERUNG	SUPPORT DE FIXATION
GC1055	LATCH	UÑETA	VERSCHLUSS	DOIGT DE RETENUE
GC1056	BUSHING	CASQUILLO	HÜLSE	DOUILLE
GC1057	PLATE (WEAR)	PLACA	PLATTE	PLAQUE
HA0181	CYLINDER (TRIGGER)	CILINDRO	ZYLINDER	CYLINDRE
HA0182	SAFETY ELEMENT ASSY	SEGURO	SICHERHEITSVORRICHTUNG	PALPEUR DE SÉCURITÉ
HC0471	CYLINDER	CILINDRO	ZYLINDER	CYLINDRE
HC0472	TRIGGER	GATILLO	AUSLÖSER	GÂCHETTE
HC0473	CYLINDER (TRIGGER)	CILINDRO	ZYLINDER	CYLINDRE
HC0474	BUSHING	CASQUILLO	HÜLSE	DOUILLE
HC0475	CYLINDER (TRIGGER)	CILINDRO	ZYLINDER	CYLINDRE
KB6315	SCREW	TORNILLO	SCHRAUBE	VIS
KB6316	WASHER	ARANDELA	SCHEIBE	RONDELLE
KB6317	SCREW	TORNILLO	SCHRAUBE	VIS
KB6318	WASHER	ARANDELA	SCHEIBE	RONDELLE
KB6319	NUT M6	TUERCA	MUTTER	ÉCROU
KB6320	NUT M4	TUERCA	MUTTER	ÉCROU
KB6321	SCREW	TORNILLO	SCHRAUBE	VIS
KB6322	PIN (SPRING)	PASADOR	STIFT	GOUPILLE
KB6323	WASHER	ARANDELA	SCHEIBE	RONDELLE
KB6324	SCREW	TORNILLO	SCHRAUBE	VIS
KB6325	SCREW	TORNILLO	SCHRAUBE	VIS
KB6326	PIN (SPRING)	PASADOR	STIFT	GOUPILLE
KB6327	SCREW	TORNILLO	SCHRAUBE	VIS
KB6328	SPRING	RESORTE	FEDER	RESSORT
KB6329	NUT M5	TUERCA	MUTTER	ÉCROU
KB6330	SPRING	RESORTE	FEDER	RESSORT
KB6331	SPRING	RESORTE	FEDER	RESSORT
KB6332	SCREW	TORNILLO	SCHRAUBE	VIS
KB6333	WASHER	ARANDELA	SCHEIBE	RONDELLE
KB6334	WASHER	ARANDELA	SCHEIBE	RONDELLE
KB6335	SCREW	TORNILLO	SCHRAUBE	VIS
KB6336	SPRING	RESORTE	FEDER	RESSORT
KB6337	SCREW	TORNILLO	SCHRAUBE	VIS
KB6338	WASHER	ARANDELA	SCHEIBE	RONDELLE
KB6339	SPRING	RESORTE	FEDER	RESSORT
LB1034	SEAL	SELLO	DICHTUNG	JOINT
LB1035	SEAL	SELLO	DICHTUNG	JOINT
LB1036	SEAL	SELLO	DICHTUNG	JOINT
LB1037	SEAL	SELLO	DICHTUNG	JOINT
LB1038	SEAL	SELLO	DICHTUNG	JOINT
LB1039	SEAL	SELLO	DICHTUNG	JOINT
LB1040	SEAL	SELLO	DICHTUNG	JOINT
LB1041	SEAL	SELLO	DICHTUNG	JOINT
LB1042	SEAL	SELLO	DICHTUNG	JOINT
LB1043	SEAL	SELLO	DICHTUNG	JOINT
LB1044	SEAL	SELLO	DICHTUNG	JOINT

Questions? Comments? call SENCO's toll-free Action-line: 1-800-543-4596 (North & South America only) or e-mail: [toolprof@senco.com](mailto:toolprof@senco.com)