

Corrugated Fastener

Operating Instructions

Instrucciones de Operacion

Mode d'Emploi

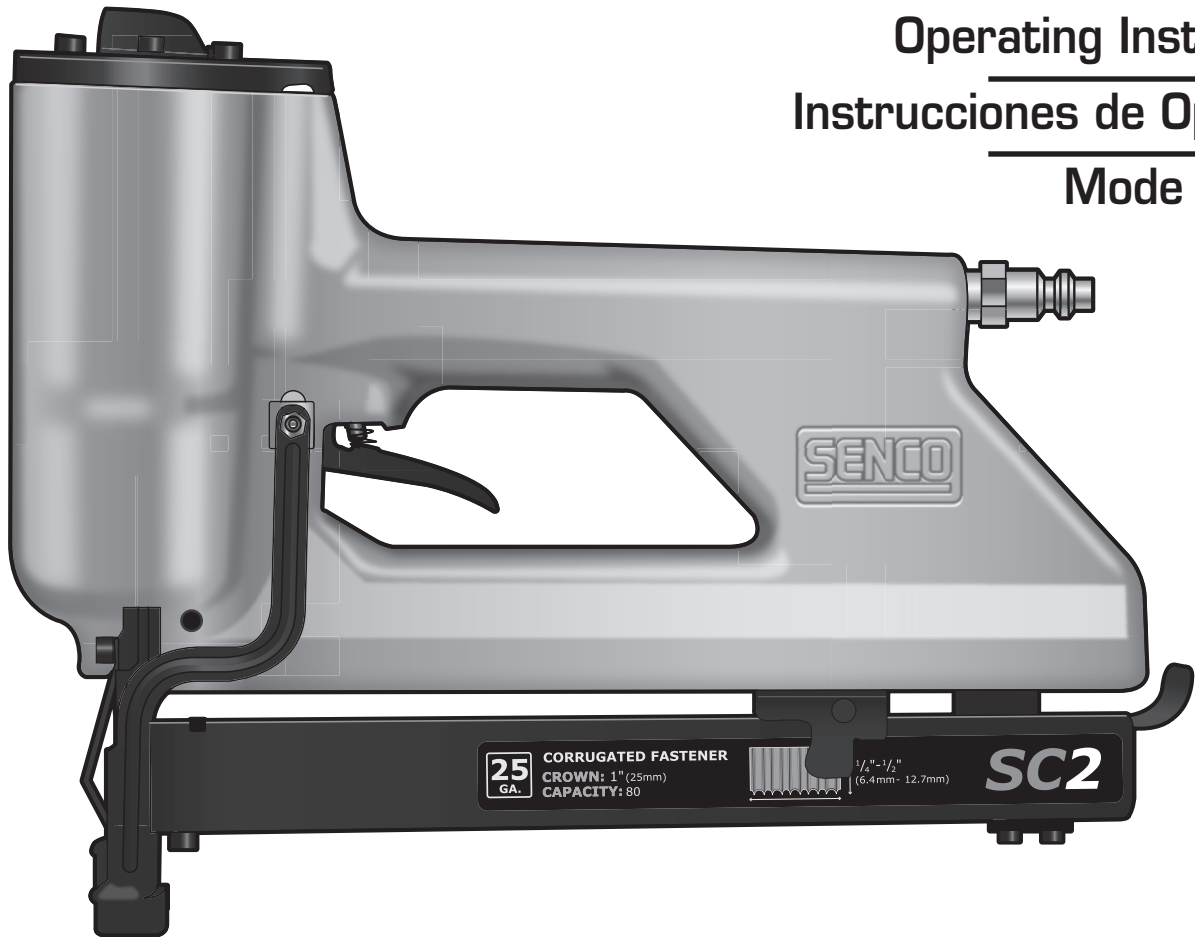

SENCO®

Senco Brands, Inc.
4270 Ivy Pointe Blvd.
Cincinnati, OH 45245
1-800-543-4596
www.senco.com



Warnings for the safe use of this tool are included in this manual.
Los avisos para el uso seguro de esta herramienta están incluidos en este manual.
Les consignes pour l'utilisation en toute sécurité de cet outil se trouvent dans ce manuel.

NFD847 Jan. 2, 2014, replaces Aug. 2, 2011

TABLE OF CONTENTS	TABLA DES MATERIAS	TABLE DES MATIERES
EMPLOYER'S RESPONSIBILITIES.....2	RESPONSABILIDADES DEL EMPLEADOR.....2	RESPONSABILITES DE L'EMPLOYEUR.....2
SAFETY WARNINGS..... 3 - 5	AVISOS DE SEGURIDAD..... 3 - 5	AVERTISSEMENTS DE SÉCURITÉ.....3 - 5
TOOL USE5 - 7	USE DE LA HERRAMIENTA.....5 - 7	UTILISATION D L'OUTIL.....5 - 7
MAINTENANCE..... 8	MAINTENIMIENTO..... 8	ENTRETIEN..... 8
TROUBLESHOOTING..... 9	IDENTIFICACIÓN DE FALLAS..... 9	DÉPANNAGE..... 9
ACCESSORIES..... 9	ACCESORIOS..... 9	ACCESSOIRES..... 9
SPECIFICATIONS.....10	ESPECIFICACIONES.....10	SPECIFICATIONS.....10
TECHNICAL SPECIFICATIONS..... 10	ESPECIFICACIONES TECNICAS.....10	SPECIFICATIONS TECHNIQUES.....10
LIMITED WARRANTY..... 11	LIMITED WARRANTY..... 11	LIMITED WARRANTY..... 11



EMPLOYER'S RESPONSIBILITIES	RESPONSABILIDADES DEL EMPLEADOR	RESPONSABILITES DE L'EMPLOYEUR
<p>Employer must enforce compliance with the safety warnings and all other instructions which accompany this tool as shipped from the manufacturer.</p> <p>Keep this manual available for use by all people assigned to the use of this tool.</p> <p>For personal safety and proper operation of this tool, read and understand all of these instructions carefully.</p>	<p>El empleador debe hacer cumplir las advertencias de seguridad y todas las otras instrucciones que acompañan a esta herramienta como se la despacha desde el fabricante.</p> <p>Mantenga este manual disponible para que lo usen todas las personas destinadas a hacer uso de esta herramienta.</p> <p>Por razones de seguridad personal y la adecuada operación de esta herramienta, lea y comprenda todas estas instrucciones cuidadosamente.</p>	<p>L'employeur doit faire appliquer les consignes de sécurité et toutes les autres instructions qui accompagnent cet outil tel qu'il est livré par son constructeur.</p> <p>Ayez ce manuel à la disposition de toutes les personnes chargées d'utiliser cet outil.</p> <p>Pour assurer la sécurité personnelle et le bon emploi de cet outil, lisez et assimilez soigneusement toutes ces instructions.</p>

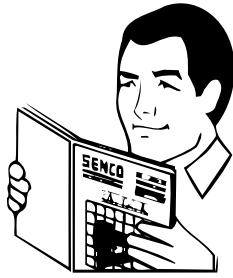

SAFETY WARNINGS	AVISOS DE SEGURIDAD	AVERTISSEMENTS DE SÉCURITÉ
<p style="text-align: center;">WARNING!</p> <ul style="list-style-type: none"> Read and understand tool labels and manual. Failure to follow warnings could result in DEATH or SERIOUS INJURY. <p style="text-align: center;">SAVE THESE INSTRUCTIONS</p>	<p style="text-align: center;">ADVERTENCIA!</p> <ul style="list-style-type: none"> Lea y comprenda las etiquetas y el manual de la herramienta. El incumplimiento de los avisos puede provocar la MUERTE o GRAVES LESIONES. <p style="text-align: center;">GUARDE ESTAS INSTRUCCIONES</p>	<p style="text-align: center;">AVERTISSEMENT</p> <ul style="list-style-type: none"> Lire et assimiler les étiquettes et le manuel de l'outil. Le non respect des avertissements peut entraîner des BLESSURES GRAVES OU MORTELLES. <p style="text-align: center;">CONSERVEZ CES INSTRUCTIONS</p>
<ul style="list-style-type: none"> Use safety equipment. Always wear ANSI Z87.1 safety glasses with permanently attached side shields. Dust mask, non-skid safety shoes, hard hat, or hearing protection must be used for appropriate conditions. Failure to do so could result in personal injury. 	<ul style="list-style-type: none"> Utilice equipos de seguridad. Use siempre anteojos de seguridad conforme a ANSI Z87.1, con protecciones laterales permanentemente colocadas. En las condiciones en las que sea necesario debe utilizarse máscara antipolvo, zapatos de seguridad antideslizantes, casco o protección auditiva. No hacerlo podría provocar lesiones personales. 	<ul style="list-style-type: none"> Utiliser un équipement de sécurité. Porter toujours des lunettes de protection classe ANSI Z87.1 avec leurs écrans latéraux montés en permanence. Quand les conditions le demandent, porter masque à poussières, casque, ou protection auditive. Ne pas porter les protections adéquates peut entraîner des préjudices physiques.
<p style="text-align: center;">PERSONAL SAFETY</p> <ul style="list-style-type: none"> Stay alert, watch what you are doing, and use common sense when operating a power tool. Do not use tool while tired or under the influence of drugs, alcohol, or medication. A moment of inattention while operating power tools may result in serious personal injury. 	<p style="text-align: center;">SEGURIDAD PERSONAL</p> <ul style="list-style-type: none"> Cuando utilice una herramienta de motor, manténgase alerta, preste atención a lo que está haciendo y aplique el sentido común. No use la herramienta cuando se sienta cansado o se encuentre bajo los efectos de drogas, alcohol o medicamentos. Un momento de falta de atención mientras utiliza una herramienta de motor puede ocasionar lesiones graves. 	<p style="text-align: center;">SÉCURITÉ CORPORELLE</p> <ul style="list-style-type: none"> Soyez en bonne condition physique, soyez attentif à ce que vous faites et faites preuve de bon sens lorsque vous utilisez un outillage électrique. N'utilisez pas votre outil si vous êtes fatigué ou sous l'influence de drogues, alcool ou médicaments. Un moment d'inattention lors de l'utilisation d'un outillage électrique peut être la cause de graves blessures corporelles.
<ul style="list-style-type: none"> EXPLOSION HAZARD Never use tool in an explosive atmosphere or in the presence of combustible materials such as flammable liquids, gases or dust. 	<ul style="list-style-type: none"> RIESGO DE EXPLOSIÓN Nunca utilice la herramienta en una atmósfera explosiva o en presencia de materiales combustibles, como líquidos, gases o polvo inflamable. 	<ul style="list-style-type: none"> DANGER D'EXPLOSION Ne jamais utiliser l'outil en atmosphère explosive ou en présence de matériaux combustibles tels que les liquides, gaz ou poussières inflammables.
<ul style="list-style-type: none"> Never use oxygen, carbon dioxide or any other bottled gas as a power source for this tool; the tool will explode and cause serious injury. 	<ul style="list-style-type: none"> Nunca use oxígeno, anhídrido carbónico o cualquier otro gas embotellado como fuente de fuerza para esta herramienta; la herramienta explotará y producirá lesiones graves. 	<ul style="list-style-type: none"> N'utilisez jamais de l'oxygène, du gaz carbonique ou tout autre gaz en bouteille comme source d'énergie pour cet outil ; cela causerait l'explosion de l'outil et entraînerait de graves blessures.



SAFETY WARNINGS

- Do not overreach. Keep proper footing and balance at all times. Proper footing and balance enable better control of the tool in unexpected situations.

AVISOS DE SEGURIDAD

- No se estire para trabajar. Mantenga en todo momento una posición adecuada y el equilibrio. La posición y el equilibrio adecuados le permiten contrarrestar mejor la herramienta ante situaciones inesperadas.

AVERTISSEMENTS DE SÉCURITÉ

- Ne présumez pas de vos forces. Restez bien stable et en équilibre à tout moment. Une position stable et bien équilibrée vous permettra de mieux réagir à une situation inattendue.

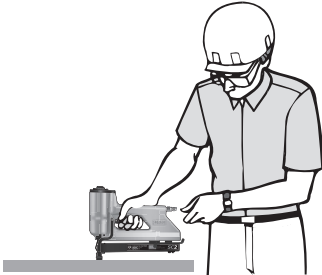

- Always assume the tool contains fasteners. Keep the tool pointed away from yourself and others. No horseplay. Respect the tool as a working implement.

- Suponga siempre que la herramienta contiene sujetadores. Mantenga la herramienta de modo que no apunte hacia usted u otras personas. Absténgase de practicar juegos rudos o bromas. Respete a la herramienta como un implemento de trabajo.

- Toujours supposer que l'outil contient encore des clous. Ne pas le pointer vers vous ou un tiers. Pas de brutalité. Respecter l'outil comme instrument de travail.



- Do not drive fasteners on top of other fasteners or with the tool at too steep of an angle; the fasteners can ricochet and hurt someone.

- No dispare los sujetadores uno encima del otro o con la herramienta en un ángulo muy empinado; los sujetadores pueden rebotar y herir a alguien.

- N'enfoncez pas des projectiles sur d'autres projectiles ou avec l'outil à un angle trop grand ; les projectiles peuvent ricocher et blesser quelqu'un.



- Disconnect tool from air before doing tool maintenance, clearing a jammed fastener, leaving work area, moving tool to another location, or handing the tool to another person.

- Desconecte la herramienta del aire antes de darle mantenimiento a la herramienta de arreglar un sujetador atascado, de dejar el área de trabajo o de mover la herramienta a otro lugar, o entregar la herramienta a otro persona.

- Couper l'arrivée d'air comprimé avant toute intervention sur l'outil (maintenance ou dégagement d'un clou coincé) ou avant de vous éloigner du secteur de travail ou avant de déplacer l'appareil, ou encore avant de le donner à une autre personne.

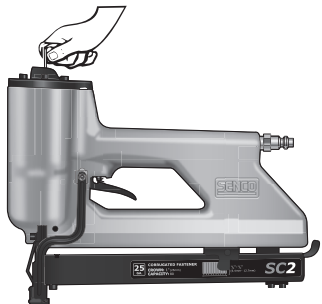

- Make sure all screws and caps are securely tightened at all times. Make daily inspections for free movement of trigger. Never use the tool if parts are missing or damaged.

- Asegúrese de que todos los tornillos y tapas estén asegurados en forma apretada, en todo momento. Realice inspecciones diarias asegurándose que el Gatillo se mueven libremente. Nunca use la herramienta si hay partes que faltan o que están dañadas.

- Assurez-vous que tous les vis et couvercles soient serrés en permanence. Par une inspection journalière, assurez-vous que la détente fonctionnent librement. N'utilisez jamais l'outil si des pièces manquent ou sont endommagées.



Safety First.  The only way to work.®

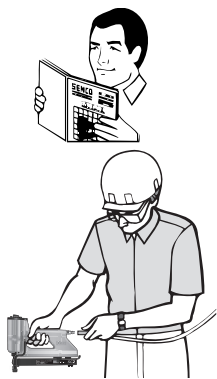

SAFETY WARNINGS	AVISOS DE SEGURIDAD	AVERTISSEMENTS DE SÉCURITÉ
<ul style="list-style-type: none"> Never use a tool that leaks air or needs repair. 	<ul style="list-style-type: none"> Nunca use una herramienta que tenga escapes de aire o que necesite reparación. 	<ul style="list-style-type: none"> N'utilisez jamais un outil qui a des fuites d'air ou qui a besoin d'être réparé.
<ul style="list-style-type: none"> Keep bystanders, minors, and visitors away while operating a power tool. Distractions can cause you to lose control. 	<ul style="list-style-type: none"> Mantenga a los acompañantes, menores y visitantes alejados mientras usted utiliza la herramienta de motor. Las distracciones pueden hacer que usted pierda el control. 	<ul style="list-style-type: none"> Maintenez les spectateurs, enfants et visiteurs à l'écart lorsque vous utilisez de l'outillage électrique. Toute distraction risque de vous faire perdre le contrôle de votre outil.
<p style="text-align: center;">SERVICE</p> <ul style="list-style-type: none"> Tool service must be performed only by Authorized Senco repair personnel. Service or maintenance performed by unqualified personnel may result in a risk of injury. 	<p style="text-align: center;">SERVICIO TÉCNICO</p> <ul style="list-style-type: none"> Las tareas de servicio técnico de la herramienta deben ser realizadas sólo por personal de reparaciones de Sencoautorizado. Las tareas de servicio o mantenimiento realizadas por personal no clificado pueden ocasionar riesgos de lesiones. 	<p style="text-align: center;">ENTRETIEN</p> <ul style="list-style-type: none"> L'entretien de l'outil ne doit être assuré que par du personnel autorisé et qualifié de Senco. De l'entretien assuré ou des réparations effectuées par du personnel non qualifié peuvent occasionner des risques d'accident.
<ul style="list-style-type: none"> For information on the "SENCO Safety First Program," contact your SENCO representative. 	<ul style="list-style-type: none"> Para información sobre el "Programa de SENCO la Seguridad es Primero" comuníquese con su representante de SENCO. 	<ul style="list-style-type: none"> Prendre contact avec votre représentant SENCO tout renseignement sur "Le Programme SENCO de Première Urgence".
TOOL USE	USE DE LA HERRAMIENTA	UTILISATION D L'OUTIL
<ul style="list-style-type: none"> Read and understand "SAFETY INSTRUCTIONS" manual shipped with this tool before using tool. 	<ul style="list-style-type: none"> Antes de usar la herramienta lea y comprenda el manual "INSTRUCCIONES DE SEGURIDAD" despachado con ella. 	<ul style="list-style-type: none"> Lisez et assimilez le manuel "INstructions de sécurité" livré avec cet outil avant de l'utiliser.
<ul style="list-style-type: none"> Keep tool pointed away from yourself and others and connect air to tool. 	<ul style="list-style-type: none"> Mantenga la herramienta apuntando en dirección opuesta de usted y de otros y conecte el aire a la manguera. 	<ul style="list-style-type: none"> Maintenez l'outil pointé à l'écart d'autres personnes et de vous-même et raccordez l'air à l'outil.

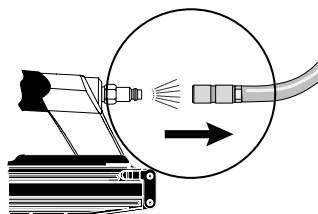
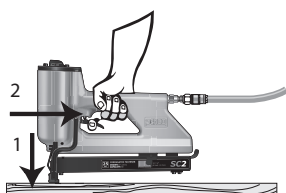
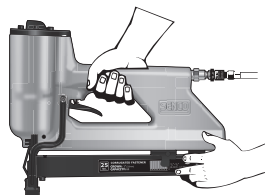
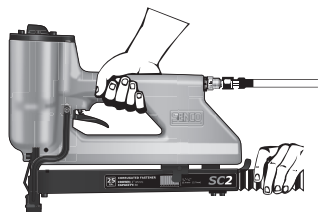
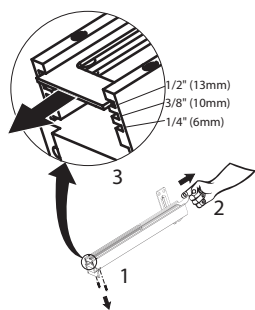

TOOL USE	USE DE LA HERRAMIENTA	UTILISATION D L'OUTIL
<p>To Load:</p> <ul style="list-style-type: none"> Adjust the magazine height before loading fasteners. (1) Remove the two outer screws on the bottom of the magazine and (2) remove the top plate. (3) Slide the top plate into the proper position for the desired fastener. 	<p>Para Cargar:</p> <ul style="list-style-type: none"> Ajuste la altura del cargador antes de cargar los sujetadores. (1) Quite los dos tornillos exteriores que están en la parte inferior del cargador, y (2) retire la placa superior (3) Deslice la placa superior en la posición que corresponda al sujetador que se va a utilizar. 	<p>Pour charger :</p> <ul style="list-style-type: none"> Réglez la hauteur de magasin avant de charger les agrafes (1). Enlevez les deux vis extérieures sur le bas du magasin et (2) sortez la plaque supérieure. (3) Faites glisser la plaque supérieure en position adéquate en fonction des agrafes voulues.
<ul style="list-style-type: none"> Insert fasteners into rear of magazine. Do not load with workpiece contact (safety element) or trigger depressed. 	<ul style="list-style-type: none"> Inserte los sujetadores dentro del cargador por la parte trasera. No cargue con el seguro o disparador presionados (activados). 	<ul style="list-style-type: none"> Introduisez les agrafes par l'arrière du magasin. Ne chargez pas avec le contact établi sur la pièce (élément de sécurité) ou la gâchette enfoncée.
<ul style="list-style-type: none"> Pull the feeder shoe back, fully, and slowly release it to engage behind the fasteners. Jamming may occur if the feeder clip is not engaged. 	<ul style="list-style-type: none"> Tire hacia atrás completamente hasta el clip de alimentación y suéltelo lentamente para que se enganche detrás de los clavos. La herramienta podría trabarse si el clip de alimentación no se engancha. 	<ul style="list-style-type: none"> Tirez le coulisseau en arrière complètement et relâchez le doucement Jusqu'à ce qu'il s'appuie derrière le clous. Les clous peuvent se coincer si le coulisseau n'est pas engagé correctement derrière les clous.
<ul style="list-style-type: none"> With a "Sequential" (Restrictive) trigger, staples can only be driven one way. First depress workpiece contact (safety element) against work surface then pull trigger. This feature is helpful when precise fastener placement is required. Read the "Customer Satisfaction and Safety Reminder" (CSSR) in the tool and fastener boxes for safety information regarding the Contact-Actuation and Sequential triggers. Under certain conditions, the Sequential (restrictive) trigger may reduce the possibility of injury to you or to others working with you. 	<ul style="list-style-type: none"> Las herramientas con "Gatillo Restringido" solamente se pueden disparar con el gatillo. Primero apriete el elemento de seguridad contra la superficie de trabajo y después tire del gatillo. Esta característica es útil cuando se requiere precisión en la colocación de los sujetadores. Lea el "Recordatorio de Seguridad y Satisfacción del Cliente" (CSSR) en las cajas de sujetadores y de las herramientas para información sobre seguridad de los Gatillos Restringido y de Acción Dual. Bajo ciertas condiciones, el Gatillo Restringido puede reducir la posibilidad de heridas a su persona o a otros que trabajen con usted. 	<ul style="list-style-type: none"> Avec une gachette "restrictive", les clous ne peuvent être tirés que dans une seule direction. Appuyer d'abord le palpeur de sécurité sur la surface de travail, puis tirer sur la gachette. Cette fonction est utile pour un placement précis de projectiles. Lire le "Rappel de Sécurité et Satisfaction du Client" (CSSR) dans les boîtes à outils et fixations pour les informations de sécurité concernant les Détentes à Double Action et à Restriction. Dans certaines circonstances, la Détente à Restriction peut réduire la possibilité de se blesser ou de blesser d'autres personnes.
<ul style="list-style-type: none"> Should a staple jam occur, disconnect air supply. 	<ul style="list-style-type: none"> Si se produce un atascamiento de las sujetadores, desconecte el suministro de aire. 	<ul style="list-style-type: none"> Si un enrayage se produit, coupez l'arrivée d'air.

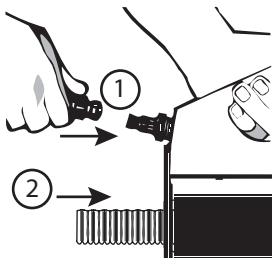
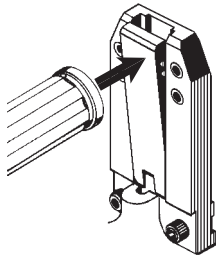
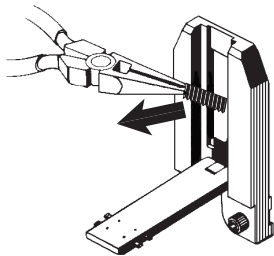
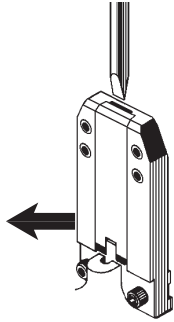

TOOL USE	USE DE LA HERRAMIENTA	UTILISATION D L'OUTIL
<ul style="list-style-type: none"> Remove fasteners from the tool. 	<ul style="list-style-type: none"> Retire los sujetadores de la herramienta. 	<ul style="list-style-type: none"> Videz le magasin de l'outil.
<ul style="list-style-type: none"> Insert the tip of a screwdriver into the driver track. Tap the handle straight down to open door. Do not twist or turn screwdriver. 	<ul style="list-style-type: none"> Introduzca la punta de un de sarmador en la abertura del cuerpo guía. Golpee el mango rectamente para abrir la puerta. No palanquee ni de vuelta al desarmador. 	<ul style="list-style-type: none"> Insérez la pointe d'un tourne-vis dans l'ouverture du guide ; Enfoncez la pointe du tourne-vis jusqu' à ouverture de la porte. Ne pas faire pivoter la pointe du tourne-vis.
<ul style="list-style-type: none"> Remove jammed fastener. 	<ul style="list-style-type: none"> Remueva el sujetador atascado. 	<ul style="list-style-type: none"> Retirez le projectile coincé.
<ul style="list-style-type: none"> Close door with a sharp tap from the screwdriver handle. 	<ul style="list-style-type: none"> Cierre la puertecilla con un golpe fuerte del mango del desarmador. 	<ul style="list-style-type: none"> Refermez la porte en tapant avec la un poignée du tourne-vis.
<ul style="list-style-type: none"> Connect air supply and replace fasteners. 	<ul style="list-style-type: none"> Conecte la línea de aire y reemplace los sujetadores. 	<ul style="list-style-type: none"> Reconnectez la conduite d'air comprimé et rechargez le magasin.

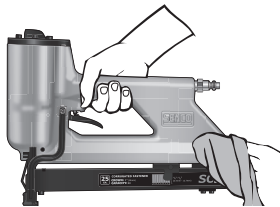
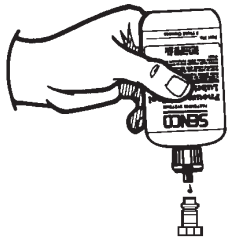
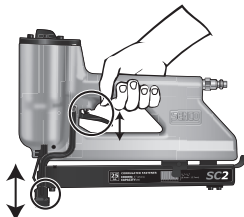
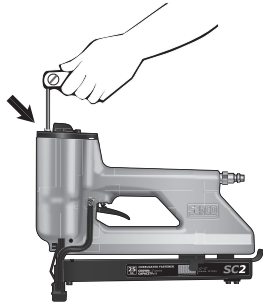
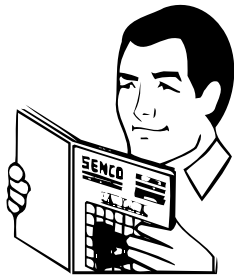

MAINTENANCE	MANTENIMIENTO	ENTRETIEN
<ul style="list-style-type: none"> Read and understand "SAFETY INSTRUCTIONS" manual shipped with this tool before using tool. 	<ul style="list-style-type: none"> Antes de usar la herramienta lea y comprenda el manual "INSTRUCCIONES DE SEGURIDAD" despachado con ella. 	<ul style="list-style-type: none"> Lisez et assimilez le manuel "Instructions de sécurité" livré avec cet outil avant de l'utiliser.
<ul style="list-style-type: none"> All screws should be kept tight. Loose screws result in unsafe operation and parts breakage. 	<ul style="list-style-type: none"> Todos los tornillos tienen que mantenerse apretados. Los tornillos sueltos pueden producir una operación no segura y quebraduras de partes. 	<ul style="list-style-type: none"> Toutes les vis doivent être maintenues serrées à fond. Les vis desserrées entraînent un manque de sûreté du fonctionnement et la rupture de pièces.
<ul style="list-style-type: none"> With tool disconnected, make daily inspection to assure free movement of trigger. Do not use tool if trigger sticks or binds. 	<ul style="list-style-type: none"> Con la herramienta desconectada, haga inspecciones diarias para asegurar un movimiento libre del disparador. No use la herramienta si el disparador se pegan o se atascan. 	<ul style="list-style-type: none"> L'outil étant déconnecté de l'arrivée d'air comprimé, effectuez une inspection journalière pour vous assurer le libre mouvement de la détente. N'utilisez pas l'outil si la détente colle ou se coince.
<ul style="list-style-type: none"> Squirt Senco pneumatic oil (5 to 10 drops) into the air inlet twice daily. (Depending on frequency of tool use.) Other oils may damage O-rings and other tool parts. 	<ul style="list-style-type: none"> Aplique aceite neumático Senco en la entrada de aire dos veces al día. (Dependiendo en la frecuencia de uso 5 A 10 Gotas.) Otros aceites pueden dañar los anillos en "O" y otras piezas de la herramienta. 	<ul style="list-style-type: none"> Avec une burette, placer 5 à 10 gouttes d'huile pneumatique dans l'arrivée d'air deux fois par jour. (Dépend de l'intensité de l'utilisation de l'appareil.) D'autres huiles pourraient endommager les joints toriques et d'autres pièces de l'outil.
<ul style="list-style-type: none"> Wipe tool clean daily and inspect for wear. Use non-flammable cleaning solutions only if necessary—DO NOT SOAK. <p>CAUTION: Such solutions may damage O-rings and other tool parts.</p>	<ul style="list-style-type: none"> Solamente si es necesario use soluciones para limpieza no inflamables -NO LA REMOJE. <p>PRECAUCIÓN: Tales soluciones pueden dañar los empaques y otras partes de la herramienta.</p>	<ul style="list-style-type: none"> Nettoyez l'outil chaque jour à l'aide d'un chiffon et inspectez-le pour déceler une éventuelle usure. Utilisez uniquement des solvants non inflammables en cas de nécessité-NE LE FAITES PAS TREMPER ! <p>ATTENTION: De tels produits peuvent endommager les joints et autres pièces de l'appareil.</p>

TROUBLESHOOTING	IDENTIFICACIÓN DE FALLAS	DÉPANNAGE
<p>WARNING</p> <p>Repairs other than those described here should be performed only by trained, qualified personnel. Contact SENCO for information at 1-800-543-4596.</p> <ul style="list-style-type: none"> Read and understand "SAFETY INSTRUCTIONS" manual shipped with this tool before using tool. 	<p>ALERTA</p> <p>Las reparaciones, fuera de aquellas descritas aquí, deben de ser llevadas a cabo solamente por personal entrenado y calificado. Póngase en contacto con SENCO para información 1-800-543-4596.</p> <ul style="list-style-type: none"> Antes de usar la herramienta lea y comprenda el manual "INSTRUCCIONES DE SEGURIDAD" despachado con ella. 	<p>AVERTISSEMENT</p> <p>Les réparations autres que celles décrites ici doivent être réalisées uniquement par du personnel qualifié ayant reçu la formation appropriée. Pour toute information, prenez contact avec SENCO par téléphone en appelant Le Distributeur agréé.</p> <ul style="list-style-type: none"> Lisez et assimilez le manuel "Instructions de sécurité" livré avec cet outil avant de l'utiliser.
SYMPTOM	SÍNTOMA	SYMPTÔME
Air leak near top of tool / Sluggish operation.	El aire se escapa cerca de la parte superior de la herramienta / Operación lenta.	Fuite d'air près du sommet de l'outil / fonctionnement lent.
SOLUTION	SOLUCIÓN	SOLUTION
Verify air supply / tighten screws or install Parts Kit A.	Apriete los tornillos / verifique el suministro de aire o instale el Juego de Partes A (Parts Kit A).	Serrez les vis à fond / vérifiez l'alimentation en air ou remplacez les pièces portant la lettre "A".
SYMPTOM	SÍNTOMA	SYMPTÔME
Air leak near bottom of tool / Poor return.	El aire se fuga cerca de la parte inferior de la herramienta / Mal retorno.	Fuite d'air près de la base de l'outil / retour inadéquat.
SOLUTION	SOLUCIÓN	SOLUTION
Clean tool / tighten screws or install Parts Kit B.	Apriete los tornillos / limpie la herramienta o instale el Juego de Partes B (Parts Kit B).	Serrez les vis à fond / nettoyez l'outil ou remplacez les pièces portant la lettre "B."
SYMPTOM	SÍNTOMA	SYMPTÔME
Other problems.	Otros problemas.	Autres problèmes.
SOLUTION	SOLUCIÓN	SOLUTION
Contact SENCO.	Póngase en contacto con SENCO.	Prenez contact avec SENCO.

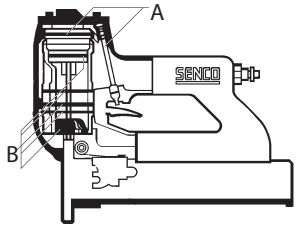

ACCESSORIES	ACCESORIOS	ACCESSOIRES
<p>SENCO offers a full line of accessories for your SENCO tools, including:</p> <ul style="list-style-type: none"> » Air Compressors » Hose » Couplers » Fittings » Safety Glasses » Pressure Gauges » Lubricants » Regulators » Filters <p>For more information or a complete illustrated catalogue of SENCO accessories, ask your representative for #MK336.</p>	<p>SENCO ofrece una línea completa de Accesorios para sus herramientas SENCO, incluyendo:</p> <ul style="list-style-type: none"> » Compresores de Aire » Manguera » Conectores Rápidos » Conectores » Anteojos De Seguridad » Manómetros » Lubricantes » Reguladores » Filtros <p>Para mas informacion ó un pour recevoir un catalogo completo ilustrado de los Accesorios SENCO, pregunte a su representante para el numero MK336.</p>	<p>SENCO offre une gamme étendue d'accessoires pour vos outils SENCO y compris:</p> <ul style="list-style-type: none"> » Compresseurs » Tuyauterie flexible » Raccords » Lunettes de sécurité » Manomètres » Lubrifiants » Régulateurs » Filtres <p>Pour plus d'informations ou pour recevoir un catalogue détaillé des accessoires proposés par SENCO, prenez contact avec votre représentant SENCO (référence catalogue : #MK336).</p>

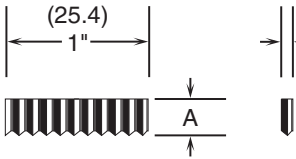
SPECIFICATIONS		ESPECIFICACIONES		SPECIFICATIONS	
Fastener	A	(25.4)	1"	25 gauge	
X04	1/4 (6.4)				
X06	3/8 (9.5)				
X08	1/2 (12.7)				

TECHNICAL SPECIFICATIONS		
Minimum to maximum operating pressure	80–110 psi	5,5–7,5 bar
Air Consumption (60 cycles per minute)	3.71 scfm	105,1 liter
Air Inlet	3/8 in. NPT	3/8 in. NPT
Maximum Speed (cycles per second)	-	-
Weight	6.9 lbs.	3,1 kg
Fastener Capacity	80	80
Tool size: Height	9 7/16 in.	240 mm
Tool size: Length	12 1/2 in.	318 mm
Tool size: Width: Main Body	3 3/16 in.	81 mm

ESPECIFICACIONES TECNICAS		
Presión de operación mínima y máxima	5,5–7,5 bar	80–110 psi
Consumo de aire (60 ciclos por minuto)	105,1 liter	3.71 scfm
Entrada de aire	3/8 in. NPT	3/8 in. NPT
Velocidad máxima (ciclos por segundo)	-	-
Peso	3,1 kg	6.9 lbs.
Capacidad de grapas por cargador	80	80
Tamaño de la herramienta: Altura	240 mm	9 7/16 in.
Tamaño de la herramienta: Longitud	318 mm	12 1/2 in.
Tamaño de la herramienta: Ancho (Cuerpo)	81 mm	3 3/16 in.

SPÉCIFICATIONS TECHNIQUES		
Pression de travail min. et max.	5,5–7,5 bar	80–110 psi
Consommation d'air (60 cycles par minute)	105,1 liter	3.71 scfm
Admission d'air	3/8 in. NPT	3/8 in. NPT
Vitesse maximum (cycles par seconde)	-	-
Poids	3,1 kg	6.9 lbs.
Capacité de projectiles par magasin	80	80
Dimensions de l'outil: hauteur	240 mm	9 7/16 in.
Dimensions de l'outil: longueur	318 mm	12 1/2 in.
Dimensions de l'outil: largeur: corps de l'appareil)	81 mm	3 3/16 in.

Limited Warranty
SENCO® Pneumatic, DuraSpin®, Cordless Tools
& Compressors

Senco Products, Inc. ("SENCO") designs and constructs its products using the highest standards of material and workmanship. SENCOWARRANTS to the original retail purchaser that the following products will be free from defects in material or workmanship for the warranty period specified below:

Pneumatic tools (both XP and Pro) Five Years	Fusion Tools Two Years	Combo Kit Tools One Year	Gas Tools Two Years
Duraspin Tools One Year	Air Compressors One Year	Multi-Blow Hand Nailers & Stapling Hammers One Year	

During the warranty period (which begins on the purchase date), SENCOWILL repair or replace, at SENCOWS option and expense, any product or part that is defective in materials or workmanship after examination by a SENCOWAuthorized Warranty Service Center, subject to the exceptions, exclusions and limitations described below. Any replacement product or part will carry a warranty for the balance of the warranty period applicable to the replaced product or part. A DATED SALES RECEIPT OR PROOF OF PURCHASE FROM THE ORIGINAL RETAIL PURCHASER IS REQUIRED TO MAKE A WARRANTY CLAIM. Warranty registration also is required and can be accomplished through on-line Product Registration at www.senco.com or by completing and returning the postage paid warranty registration form included with your Operator's manual/parts chart information, found inside the product carton. To make a warranty claim, you must return the product, with proper receipt/proof of purchase and return transportation charges prepaid, to a SENCOWAuthorized Warranty Service Center. A list of SENCOWAuthorized Warranty Service Centers can be found at www.senco.com or by calling 1-800-543-4596 toll free. SENCOWwill perform its obligations under this warranty, within a reasonable time after approval of the warranty claim.

Wheelbarrow Compressors:

- Subject to the exceptions, exclusions and limitations described below, SENCOWARRANTS that the compressor pump will be free from defects in materials and workmanship for two years after the purchase date.
- Defective parts of the compressor pump not subject to normal wear and tear will be repaired or replaced, at SENCOWS option, during the two year warranty period. If SENCOWdetermines that repair or replacement is not feasible, SENCOWwill refund the purchase price less reasonable depreciation based on actual use.

SENCOWCordless:

- Subject to the exceptions, exclusions and limitations described below, SENCOWARRANTS that the SENCOWCordless tool will be free from defects in materials and workmanship for two years after the purchase date.
- SENCOWwarrants that the batteries and chargers used with SENCOWCordless tools will be free from defects in material and workmanship for one year after the purchase date.

WARRANTY EXCLUSIONS

The following warranty exclusions apply:

- Normal wear parts are not covered under this warranty. Normal wear parts include, for example, isolators, drive belts, air filters, rubber o-rings, seals, driver blades, piston stops, and piston/driver assembly.
- This warranty does not cover parts damaged due to normal wear, misapplication, misuse, accidents, operation at other than recommended speeds or voltage (electric units only), improper storage, or damage resulting during shipping.
- Products used in production/industrial applications as defined by SENCOWare excluded from this warranty.
- Labor charges or loss or damage resulting from improper operation, maintenance or repairs are not covered by this warranty.
- SENCOWdoes not warrant the Wheelbarrow Compressor Engine/Motor, but the Compressor Engine/Motor may be covered under a warranty offered by its manufacturer.

GENERAL WARRANTY CONDITIONS

This warranty will be honored, only if:

- Clean, dry, regulated compressed air has been used, at air pressure not exceeding the maximum indicated on the tool casting;
- No evidence of abuse, abnormal conditions, accident, neglect, misuse or improper modifications or storage of the product; and
- No Deviation from operating instructions, specifications, and maintenance schedules exists (read Operator Manual for use, specifications, and maintenance instructions).

THIS WARRANTY IS THE ONLY WARRANTY ON THE PRODUCT, AND SENCOWDISCLAIMS ALL OTHER WARRANTIES. ANY IMPLIED WARRANTIES WILL BE LIMITED IN DURATION TO THE APPLICABLE WARRANTY PERIOD SPECIFIED ABOVE. SOME STATES DO NOT ALLOW LIMITATIONS ON HOW LONG AN IMPLIED WARRANTY LASTS, SO THE ABOVE LIMITATION MAY NOT APPLY TO YOU. YOUR REMEDIES ARE SOLELY AND EXCLUSIVELY AS STATED ABOVE. SENCOWSHALL IN NO EVENT BE LIABLE FOR INCIDENTAL, CONSEQUENTIAL, INDIRECT, OR SPECIAL DAMAGES. SOME STATES DO NOT ALLOW THE EXCLUSION OR LIMITATION OF INCIDENTAL OR CONSEQUENTIAL DAMAGES, SO THE ABOVE LIMITATION OR EXCLUSION MAY NOT APPLY TO YOU. IN NO EVENT, WHETHER AS A RESULT OF A BREACH OF CONTRACT, WARRANTY, TORT (INCLUDING NEGLIGENCE) OR OTHERWISE, SHALL SENCOWS LIABILITY EXCEED THE PRICE OF THE PRODUCT WHICH HAS GIVEN RISE TO THE CLAIM OR LIABILITY. ANY LIABILITY CONNECTED WITH THE USE OF THIS PRODUCT SHALL TERMINATE UPON THE EXPIRATION OF THE WARRANTY PERIOD SPECIFIED ABOVE. NO EMPLOYEE OR REPRESENTATIVE OF SENCOWOR ANY DISTRIBUTOR OR DEALER IS AUTHORIZED TO MAKE ANY CHANGE OR MODIFICATION TO THIS WARRANTY.

This warranty gives you specific legal rights, and you may also have other rights which vary from state to state.

REPLACEMENT OF TOOL DUE TO NATURAL DISASTER

SENCOWwill replace any tool destroyed by an Act of God such as flood, earthquake, hurricane or other disaster resulting only from the forces of nature. Such a claim will be honored provided that such original retail purchaser had previously submitted a completed warranty registration card for the tool, and then submits proof of ownership and an acceptable statement describing such Act of God documented by an insurance carrier, police department, or other official governmental source. To obtain instructions for filing a claim call 1-800-543-4596.

CUSTOMER SATISFACTION

One hundred percent customer satisfaction is our #1 goal. If for any reason the product does not perform to the original purchaser's satisfaction, it can be returned to the place of purchase **within thirty days** with dated sales receipt for a full refund of the purchase price.